

STURDY 770lt CLINICAL WASTE BIN



- Containers approved for the transport of hazardous, e.g. infectious, waste
- Directional wheel Locks on 2 Wheels allow for towing
- Lid Lock comes as standard on all bins
- Non Marking Wheels for Hospitals are an optional extra
- Easy handling
- Easy filling
- Easy grip handles on front and sides of lid
- Stable and light weight lid
- Safe manoeuvring
- Easy grip handles on three sides
- Wide handles, easy to use when wearing thick gloves
- User-friendly handles
- Handles available in alternative colours
- Complies fully with EN or RAL quality requirements
- Versatile, with a comprehensive accessories range
- Various wheel assembly configurations for different applications
- Water drainage plug as standard
- Compatible with identification and weighing systems
- Suitable for all lifting equipment in accordance with EN 840
- Rounded lid profile for improved rainwater dispersal

Dimensions and Weights

- Nominal volume: 770 litres
- Net weight: ca. 46 kg
- Permitted total weight: 360 kg

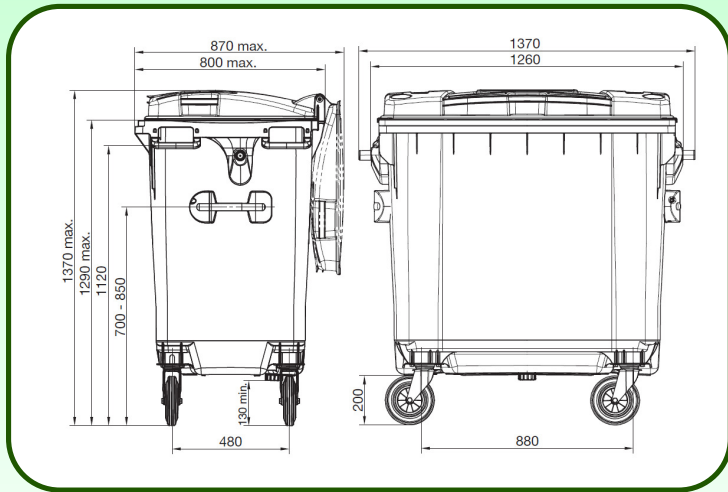

Material and Design

- Polymer components injection moulded from specially designed HDPE
- Resistant to decay, frost, heat and many chemicals
- Special UV-stabilisation provides excellent ageing characteristics
- Additives are cadmium free and environmentally friendly
- Metal components are corrosion resistant
- Quiet-running solid rubber tyres
- Suitable for all DIN lifting equipment
- Compatible with identification and weighing systems
- Fitted as standard with chip nest in accordance with RAL GZ 951/1
- High quality materials and most advanced manufacturing processes guarantee a long service life
- All container parts are recyclable

Quality

- Certified according to EN 840 and RAL GZ 951/1
- Constant quality control through own laboratory as well as independent institutes

Approvals

- KAB 770: (H) 50H

Colours

- Standard colour for Clinical Waste Bin is yellow
- Other colours include grey, green, blue, yellow, brown, red
- Special colours are available on request
- All additives are cadmium free and environmentally friendly



Markings

- (H) - number
- Text: Clinical Waste + Infectious Substance
Clinical Waste Unspecified N.O.S. UN 3291
- Logo: Infectious Substance Class 6 (hazardous goods)
- Serial number

