

# **Standard for Sloping Musoir Pole**

NO: T.E.L. - 607 - Rev 2-15.

Revised: September 2015

**This document is intended for the exclusive and non collective use of Irish bodies involved in road safety and standards. All network exploitation, reproduction and re-dissemination, even partial, whatever the form (hardcopy or other media) is strictly prohibited.**

# STANDARD FOR SLOPING MUSOIR POLE

## NO: T.E.L. - 607 - Rev 1-12.

S.F.P 67

### Contents

1.	SCOPE: .....	3
2.	NORMATIVE REFERENCE .....	3
3.	DEFINITION .....	3
4.	DESIGN REQUIREMENTS.....	4
4.1.	The Product must imperatively;.....	4
4.2.	Height .....	4
4.3.	Cross Section .....	4
4.4.	Sloping Design.....	4
4.5.	Thickness .....	4
4.6.	Base Fixing .....	4
4.7.	Adjustment.....	5
4.8.	Receptacle Design.....	5
4.9.	Unit Design.....	5
4.10.	Method of Fixing.....	5
4.11.	Reflective Material .....	5
4.12.	Reflective Material Pattern.....	5
5.	MATERIAL PROPERTIES .....	6
5.1.	Density - (Raw materials) .....	6
5.2.	Melt Flow Rate (Raw Materials) .....	6
5.3.	Weather Resistance.....	6
5.4.	Steel Base Receptacle .....	6
6.	SLOPING MUSOIR POLES DESIGN PROPERTIES.....	6
6.1.	Height and Tolerance.....	6
6.2.	Visual Inspection .....	6
6.3.	Weight .....	6
6.4.	Wall Thickness .....	6
6.5.	Colour .....	6
7.	SLOPING MUSOIR POLES TESTING .....	7
7.1.	Impact Test & Classification ; .....	7
7.2.	Impact Test Positioning; .....	7
7.3.	Test frequency .....	7
7.4.	Wind load Test.....	8
8.	FINISH OF METAL PARTS .....	8
9.	Markings:.....	8
9.1	CE Marking .....	9
	<i>Fig. 2 Example CE marking information for Sloping Musoir Pole</i> .....	9
10.	PRODUCTION AND QUALITY CONTROL .....	10
11.	HANDLING AND USE.....	10
	Annexe A .....	11
	Plastic Sloping Musoir Pole .....	11

# STANDARD FOR SLOPING MUSOIR POLE

## NO: T.E.L. - 607 - Rev 1-12.

S.F.P 67

### 1. SCOPE:

This standard specifies the requirements for thermoplastic Sloping Musoir Poles for use on National Roads and Motorways, including their fixing. This standard applies to Sloping Musoir Poles that are open and not subject to any over pressure and having a height between 2.0m and 3.0m.

It covers performance requirements and test methods, colorimetric and retro-reflective properties are specified taking into account International Commission on Illumination (CIE) recommendations.

The purpose of the standard is to define the material used, requirements, tests, type tests and production quality control tests.

Provision is made for safety in use, including vehicle impact. Trans-illumination products are not covered in this standard.

Companies manufacturing to the standard must be certified to I.S. EN 9001:2008 or equivalent.

### 2. NORMATIVE REFERENCE

This Standard incorporates by dated or undated reference from other publications. These 'normative' references subsequent amendments to, or revisions of, any of these publications apply to this standard only when incorporated in it by amendment or revision. For undated reference the latest edition of the publication referred to applies.

ISO 1133 - 1981	Plastics Determination of the Melt Flow Rate of Thermoplastics.
ISO 1183	Plastics: Method of determining density.
I.S. EN 527 - 1995	Determination of Tensile Properties.
I.S. EN 12899- 3: 2007	Fixed Vertical Road Traffic Signs 3; Delineator Post & Retroreflectors.
I.S. EN 12899-1: 2007	Fixed Vertical Road Traffic Signs 1; Fixed Signs
ISO 175	Plastics: Determination of the effects of liquid chemicals, including water.
ISO 1872 – 1986	Plastics: Test specimen preparation.
EN 45020	General terms and their definition concerning standardisation and related activities.
EN ISO 877: 1996	Plastics- Method of exposure to direct weathering, to weathering using glass-filtered daylight, and to intensified weathering by daylight using Fresnel mirrors (ISO 877-1994).
ISO 1461	Hot Dipped Galvanising
I.S. EN 12767: 2007	Passive Safety of Support Structures for Road Equipment- Requirements, Classification and Test methods.
EN 45020	General terms and their definitions concerning standardization and related activities

### 3. DEFINITION

A Sloping Musoir Pole is a marker post to indicate a point of divergence in road lanes, where the “Chevron” area is tight and standard Monolithic Musoirs or Musoir Poles are impractical to use. They are specifically designed to improve traffic safety. Monolithic Musoirs and Musoir Poles are dealt with under different standards. A Sloping Musoir Pole is a product that retains its design shape for the purpose of guiding road traffic at point of divergence of laneways. It stands without any external support other than base fixing detail having reflective panels as specified in National Standards.

# STANDARD FOR SLOPING MUSOIR POLE

NO: T.E.L. - 607 - Rev 1-12.

S.F.P 67

Decor: A series of reflective arrowheads along the length of the pole to indicate divergence in road lanes.

## 4. DESIGN REQUIREMENTS

### 4.1. The Product must imperatively;

- Be clearly seen and identified by road users either by day or by night,
- Identify precisely the area of divergence,
- Be capable of staying in place,
- Be easy to install and quickly replaceable,
- Not be deemed in themselves to be a dangerous obstacle.
- Be capable of being seen from a distance of 30M and over the roof of a normal domestic vehicle.

### 4.2. Height

The Sloping Musoir Poles should be available individually or as part of a set capable of alerting traffic to up coming road divergence. The Poles should be capable of erection in a variety of configurations, or surfaces.

Its design should be flat or slightly curved / indented in shape, which does not have sharp corners or sharp edges. The non aggressive edge will be measured by checking the edges are finished in a rounded shape, measuring minimum of 1.4 mm.

The Sloping Pole should be in a trapezoidal shape decreasing towards its uppermost point, The Pole should be a height in the vertical plane of 2.4 M +/- 5% and the base should be not more than 750mm +/-5%. The Pole has, on the traffic facing side a series of 7 No. pairs of white equilateral triangles. These triangles are composed from a Class 2 retro-reflective sheeting or as the Road Design Engineer specifies; their sides are 200 mm +/- 5%. See Appendix A for diagram of the Sloping Pole.

### 4.3. Cross Section

The cross section of the unit should be a maximum of 600mm tolerance +/- 5% at the base of the body and minimum of 200mm +/- 5% at the top and of such a design so as to facilitate the placing of the reflective markings above. Its design should be of such shape so as to give adequate surface facing oncoming vehicles to enable safe alerting of traffic. The design should be such, so as to cater for national wind and temperature conditions.

### 4.4. Sloping Design

The pole should when erected slope away from oncoming traffic at an angle of 105 deg to the horizontal +/- 5%.

### 4.5. Thickness

The Units should be manufactured to give a minimum wall thickness of 5mm and a maximum thickness of 8mm +/- 10% tolerance. Only virgin material should be used. The product should however be fully recyclable and the supplier should offer a “take back recycling service”.

### 4.6. Base Fixing

The base fixing detail should be of such design so as to allow for rapid replacement of damaged units. It should incorporate a facility to enable fixing and adjusting of the pole in the vertical position. The fixing detail should incorporate external fixings to ensure that misalignment will not occur after erection due to wind or draft from passing traffic.

# STANDARD FOR SLOPING MUSOIR POLE

## NO: T.E.L. - 607 - Rev 1-12.

S.F.P 67

### 4.7. Adjustment

The design of the system should be such, that it allows base receptacle adjustments to be available with regard to installation position layout. Each location layout should be specified by the road design engineer or delegate.

### 4.8. Receptacle Design

The base receptacle design should be of such design so as to accommodate it's fixing in the ground by placing it in a concrete surround, and be of adequate design to give stability in all national wind conditions. The base foundation should be of adequate design to pass impacting testing as set out below.

### 4.9. Unit Design

The base of the pole should be of such design so as to facilitate the shearing off, of the pole at the base of the unit upon impact.

### 4.10. Method of Fixing

The pole should be fixed to the ground by means of weakened foot/base section of the same material as the Pole. These are either directly moulded into the pole or fixed to the pole with the aid of non metallic bolts.

Gluing of the foot to the pole is strictly forbidden.

### 4.11. Reflective Material

The white/coloured triangular sticker material should be retro-reflective. The retro- reflective stickers with white/coloured background should be to class 2 or as defined by the Road Design Engineer, as defined in EN 12899-1:2007.

The self adhesive coverings are applied uniquely to the front part of the poles; they should be completely attached to the pole. The material should be "as new" after the testing set out below.

### 4.12. Reflective Material Pattern

The front face has a graphic detail which is triangular in shape, white on colour blue or green background. This will be decided by National Standards Authority or by the Road Design Engineer in the installation area.

# STANDARD FOR SLOPING MUSOIR POLE

## NO: T.E.L. - 607 - Rev 1-12.

S.F.P 67

### 5. MATERIAL PROPERTIES

#### 5.1. Density - (Raw materials)

The use of reground material shall not be permitted.  
Determined in accordance with ISO 1183 method A or D. A single resin polymer shall have a density not less than 890kg/m<sup>3</sup> and not greater than 940kg/ m<sup>3</sup>.

#### 5.2. Melt Flow Rate (Raw Materials)

The melt flow rate, (measured in accordance with ISO 1133 Section 4), must be a maximum of 10g/ 10min and a minimum 3g/ 10min.

#### 5.3. Weather Resistance

The material used in the manufacture of the body shall be ultra violet light stabilised to a minimum of UV 8 and the material should be certified to have a colour fastness on the “Blue Wool Scale” of not less than 6. A 3,000 hour weathering test shall be completed on the material it shall be carried out on a prepared sample of the rotationally moulded material, the outer surface should be exposed to UV radiation in accordance with EN ISO 4892-1 and EN ISO 4892-2.  
The relative change in Tensile Elongation shall be less than 50%.  
The colour fastness shall not have significantly deteriorated.

#### 5.4. Steel Base Receptacle

Manufactured from steel to BS.1387 with a minimum wall thickness of min 3mm. and a tolerance of +/- 5%.  
All fabrication of steel components to be completed by certified welder in accordance with EN 287-1.

### 6. SLOPING MUSOIR POLES DESIGN PROPERTIES

#### 6.1. Height and Tolerance

When measured, the ambient temperature shall be 15°C ± 5°C. The height of each unit shall measure from the top of the base fixing point to the upper top point of the unit to an accuracy of ± 10%.

#### 6.2. Visual Inspection

On visual inspection of the Pole there should be no bubbles, blisters, or other defects that could cause a hole or fracture, the product should be aesthetically pleasing and free from warping.

#### 6.3. Weight

The Maximum weight of any Pole, measured with any attachments, shall not be more than 20kg. Tolerance in these weights shall be +20%.

#### 6.4. Wall Thickness

The minimum wall thickness on any point of the sides or base shall not be less than 5mm. A margin of 10% is permitted.

#### 6.5. Colour

The Colour of the unit shall be;  
Blue; RAL 5019 or British Standard 381C No 109 (Middle Blue) for Motorway use, or Blue; RAL 5009

# STANDARD FOR SLOPING MUSOIR POLE

## NO: T.E.L. - 607 - Rev 1-12.

S.F.P 67

Green; RAL 6003 or British Standard 381C No 225 (Light Brunswick Green) for National Roads, Or Green; RAL 6001

“Colours from BS381C are given for comparative purpose only. In practice, the colour of all signs will comply with chromaticity requirements of BS873; Parts 6 or BS EN 12899-1” or may be as dictated by National Authority preference in area of installation.

### 7. SLOPING MUSOIR POLES TESTING

The Pole, complete with all its base framework and fixings, shall be subject to an impact and load test as follows:

#### 7.1. Impact Test & Classification ;

The Product shall be tested in accordance with EN12767:2007 as applicable.

#### 7.2. Impact Test Positioning;

- (a) The Sloping Pole shall be fixed to the ground in accordance with manufactures instructions.
- (b) The Sloping Pole shall be erected in the vertical position or if designed otherwise in accordance with the design criteria.
- (c) The test position shall be on a level surface with adequate surface to simulate Motorway or National Road conditions.
- (d) Result: results shall be recorded by means of video and photographic evidence and shall be certified by a Director of the Manufacturing Company or an independent external certification body as having passed the tests.

#### 7.3. Test frequency

- (i) Dimension Measurement is a type test and shall be completed prior to certification, once off, ref. 4.2 and 6.1.
- (ii) Weight: The weight of the pole as defined in 6.3 shall be tested every 3 months from samples randomly picked from production, or one in every 500 units manufactured.
- (iii) Impact Test. This is a design type test and shall be completed once before certification. Should the design of the Pole change in any way this test must again be repeated.
- (iv) Visual inspection: Every Pole.
- (v) Wall thickness: From production, once every 3 months on sample of each size of Pole or from one in every 500 manufactured.

# STANDARD FOR SLOPING MUSOIR POLE

## NO: T.E.L. - 607 - Rev 1-12.

S.F.P 67

### 7.4. Wind load Test.

The Pole shall be subjected to a wind test.

The Pole should be able to resist the force required to withstand wind pressure of  $(90 \pm 5)$  daPa (which corresponds to a speed of about 137km/hr).

The test is carried out, at a temperature of  $(15 \pm 3)$  °C on the traffic facing surface of the Pole. Force is applied, by way of 2 daN load, with the centre of gravity of the pressure forces mid point and at the end point of the Pole, in accordance with the diagram below, i.e. applied at the centre point of the longest side, and extremity.

The deflection at the outer most extremity of the Pole should less than 10mm.

The deflection of the Pole at the centre point when loaded shall be less than 2mm.

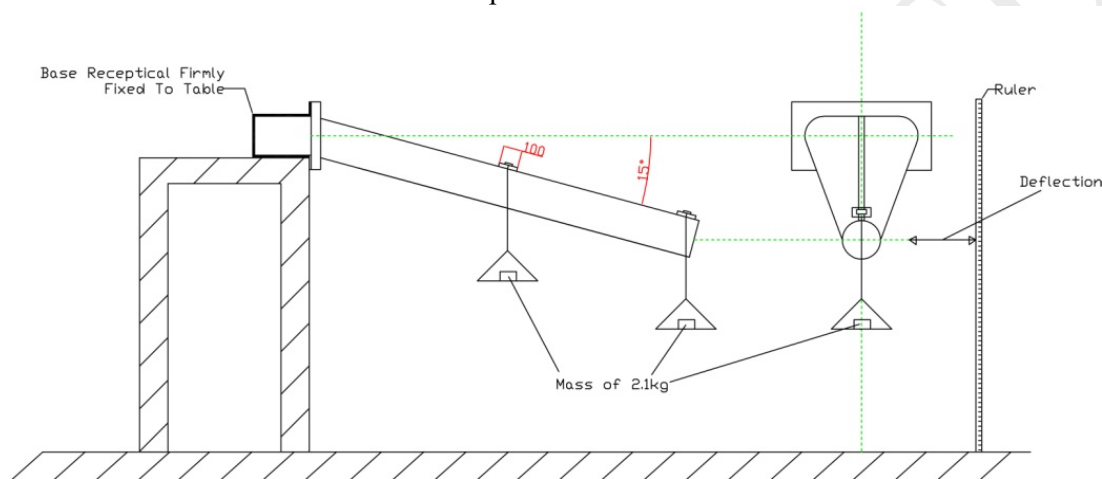

**Figure 1: Test of Stability**

### 8. FINISH OF METAL PARTS

All metal parts shall be protected as follows.

Frame;	Where it is to be set in concrete a clean un-oiled surface may be provided.
Exposed surface;	The top surface of the base receptacle shall be wire brushed and treated with an epoxy paint or similar
Nut / bolt fixings;	Shall be galvanised or stainless steel or better.

### 9. MARKINGS:

The following information should be marked on each Pole:

- Height;
- Year of Manufacture;
- Standard to which manufactured to;
- Name and contact details of manufacturer;



# STANDARD FOR SLOPING MUSOIR POLE

## NO: T.E.L. - 607 - Rev 1-12.

S.F.P 67

### 9.1 CE Marking

The manufacturer or their authorised representative established within the EEA is responsible for the affixing of the CE marking.

The CE marking shall appear on the product or on an attached durable label. Additionally, the CE marking (in accordance with Directive 93/68/EEC) and the following information shall appear on the packaging and/or shall be shown on the accompanying commercial documents:

- The identification number of the notified body (if relevant)
- the name or identifying mark of the producer supplier
- the last two digits of the year in which the marking was affixed
- the appropriate number of the certificate of conformity (if relevant)
- the number of this standard
- the product name and type of Product
- information on the relevant essential characteristics

*Fig. 2 Example CE marking information for Sloping Musoir Pole*

 13 0913- Retroreflective 1719- Material XXXX XXXX
Sturdy Products Ltd. Blessington Industrial Estate, Blessington, Co. Wicklow, Ireland
Certificate Number: 00001
<b>STURDY Sloping Musoir Pole</b>
<b>Relevant Standards</b> I.S. EN 12899 – 3: 2007 “Fixed, Vertical Road Traffic Signs- Part 3: Delineator Posts and Retroreflectors”. I.S. EN 12899 - 1: 2007 “Fixed, Vertical Road Traffic Signs- Part 1: Fixed Signs”. I.S. EN 12767: 2007 “Passive Safety of Support Structures for Road Equipment, Requirements, Classification and Test Methods”.
<b>EN 12899 – 3: 2007;</b> 5 – Types of delineator post and retroreflector - Pass 6.1 – Performance Requirements (General) - Pass 6.2 - Performance Requirements (Fixing retroreflectors on delineator posts) - Pass 6.3 - Performance Requirements (Visual performance) - Pass 6.4.1.1 – Physical Performance (Static Requirement) - Pass 6.4.1.2 - Physical Performance (Dynamic impact resistance) - Pass 6.4.1.6 – Physical Performance (Natural weathering) - Pass 8 – Marking, Labelling and Product information - Pass 9 – Evaluation of conformity - Pass 10 – Dangerous Substances - N/A
<b>EN 12899 – 1: 2007;</b> XXXX
<b>EN 12767: 2007;</b> 5.2 – Basic Requirements (Predictable Behaviour) - Pass 5.2 - Basic Requirements (Vehicle Behaviour) - Pass 5.4 – Deemed to comply - Pass 5.5 – Selection of items for test and product families - Pass 5.6 – Non- harmful support structures - Pass

*Fig. 2* gives an example of the information to be given on the packaging and/or on the accompanying commercial documents for the Pole.

**STANDARD FOR SLOPING MUSOIR POLE**  
**NO: T.E.L. - 607 - Rev 1-12.**

S.F.P 67

**10. PRODUCTION AND QUALITY CONTROL**

The tests described in section 7 of this standard should be carried out at the frequency indicated above during production with quality control, and other records maintained within a quality system. This system should be audited and certified by a Certified External Authority in accordance with CEN regulator EN 45020.

**11. HANDLING AND USE**

The manufacturer should supply instructions for the handling and fitting of the Pole.

---

**STANDARD FOR SLOPING MUSOIR POLE**  
**NO: T.E.L. - 607 - Rev 1-12.**

S.F.P 67

**ANNEXE A**  
**Plastic Sloping Musoir Pole**  
 (Dimensions in mm)

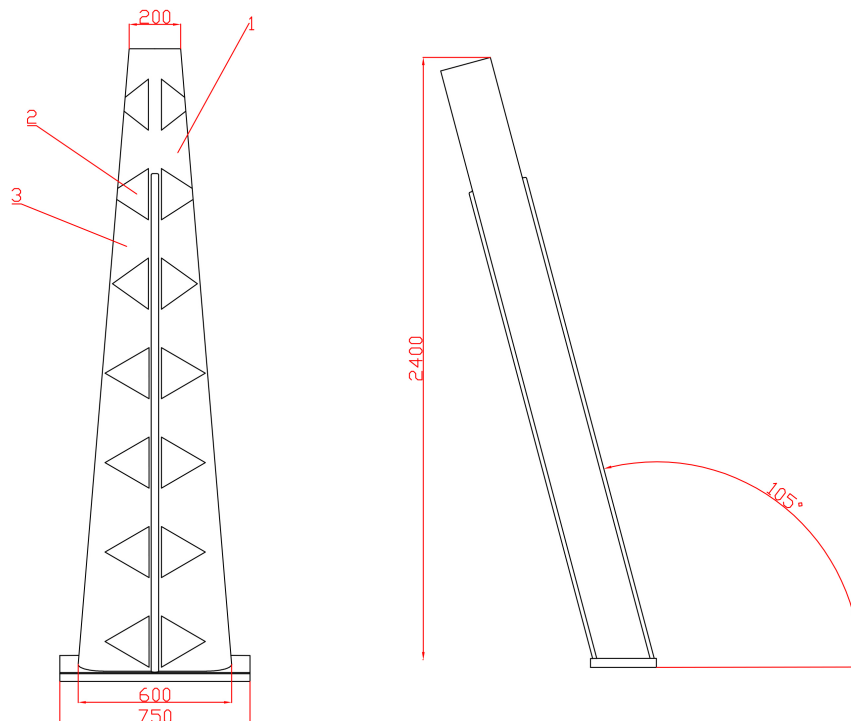

1. Pole
2. White
3. Blue / green
4. Dimension Tolerances +/- 2%

Fixing detail; Quick replacement to manufacturers detail securely fixed to ground