

STURDY
PRODUCTS LTD

Construction

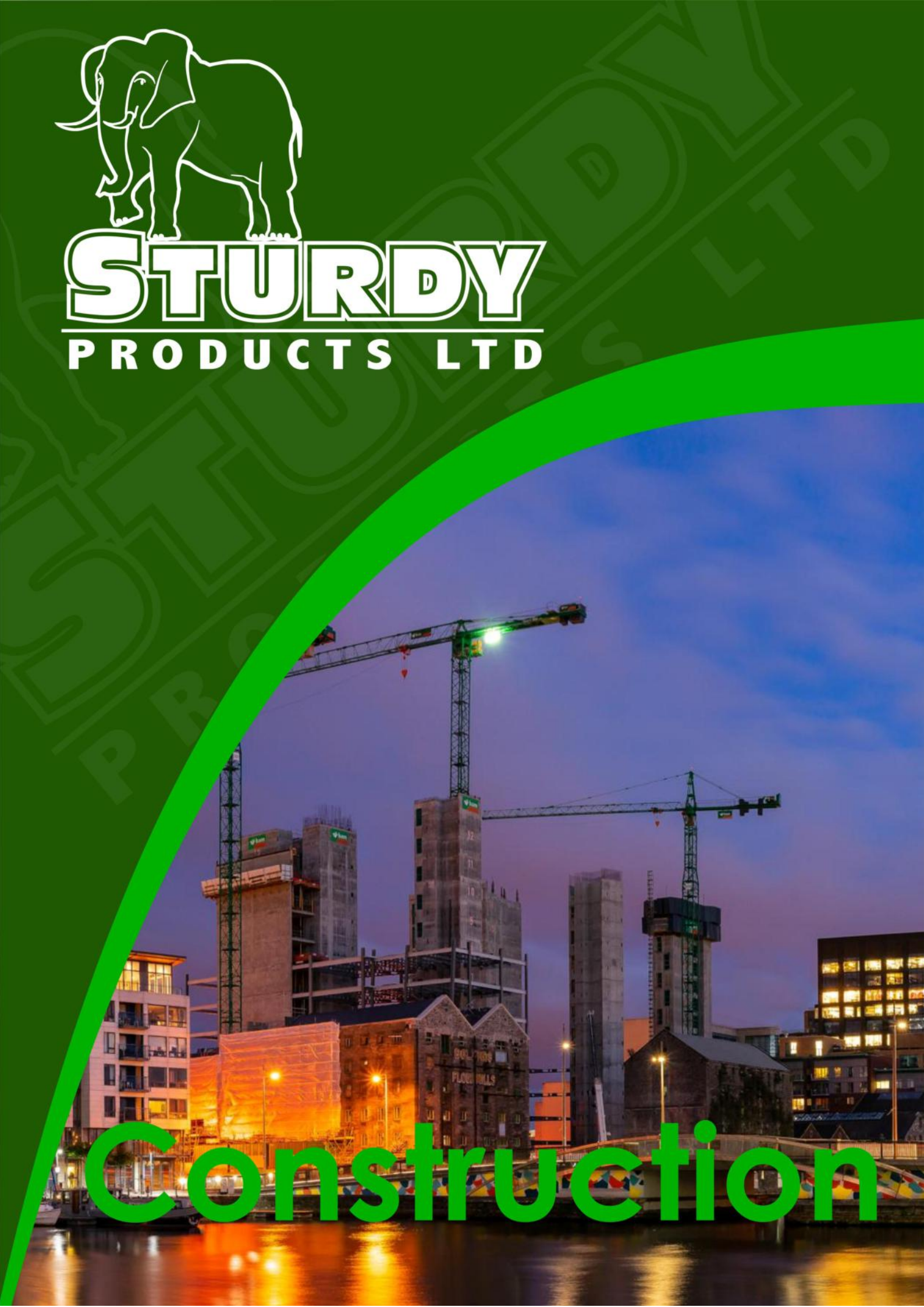

Mortar Tubs

The Sturdy 330L Mortar Tubs are the highest quality mortar tub on the market. They are designed for crane and teleporter use.

These fully tested, certified and approved to international standards Mortar Tubs ensure safety and compliance on your building site. Full certification is available for each tub supplied.

- Extremely strong, durable, highest quality mortar tub.
- Unique patented 'Flexi' Handles.
- Complete with galvanised metal frame and handles.
- Designed for crane or teleporter use.
- Stacking lugs prevent tubs from sticking when stacked.
- Signage panel for personalisation.
- Available in a range of colours.

Optional extra

Sturdy Liner Bags ensure a longer life for the mortar tubs, and prevents mortar solidifying. The liner bags also reduce the time required for cleaning and prolongs the on-site usable time for your mortar.

Product Code: 092- A [Roll of 100 bags]



Craneable:
Capacity 330L
Width 700mm
Length 1000mm
Height 700mm
Product Code 036- A



Teleporter:
Capacity 330L
Width 700mm
Length 1000mm
Height 700mm
Product Code 325- A

330L Skip Trolley

The Sturdy Skip Trolley is ideal for transporting materials on a construction site or in industry.

This wheel mounted Skip Trolley has 100mm wheels and can be crane lifted by its lifting handles.

- Cost effective and practical buggy.
- Optional lifting frame available.
- Lightweight and easy to manoeuvre.
- Strong and durable to withstand use on construction sites.
- Fitted with standard components.
- Signage panel for personalisation.



330L Skip Trolley
Capacity 330L
Width 710mm
Length 1025mm
Height 960mm
Product Code 360- A

Tote Buggy

The Tote Buggy is ideal for transporting and storing goods in the workplace.

Manufactured from medium density polyethylene UV stabilised the Tote Buggy is extremely strong, durable and maintenance free. It is lightweight and easy to manoeuvre. It can be supplied with a PVC or wooden top.

The Tote Buggy is available in a range of colours.

Optional extra

- PVC cover
- Hard plastic lid



Craneable:
Capacity 330L
Width 700mm
Length 1000mm
Height 960mm
Product Code 148- A

Mortar Tub Trolley

Product Guide:

330LT

Product code: 036-A

250LT

Product code: 060-A



- The **Mortar Tub Trolley** is developed to accommodate two different sizes of Mortar Tubs. By default the product is developed for the smaller 250lt Tub however its extension frame allows for the larger 330lt tub to be used as well.
- The bottom part of the **extension frame** is made out of angled iron, which allows for comfortable fit and operation. Due to tight fit, there are no extra fittings required to fix it in place, meaning the extension frame simply sits on top of the default frame making it very easy to switch between tubs.

Mortar Tub Trolley

Dimensions Open
Length: 1910mm
Width: 880
Height: 1510mm

Dimensions Closed
Length: 1910mm
Width: 880
Height: 840mm

Product Code
661- A

Bottom of the frame made from angled iron to allow tight fit

Plug&Play Extension frame
(No need for any fixings)

Designed to sit
on top of existing
frame

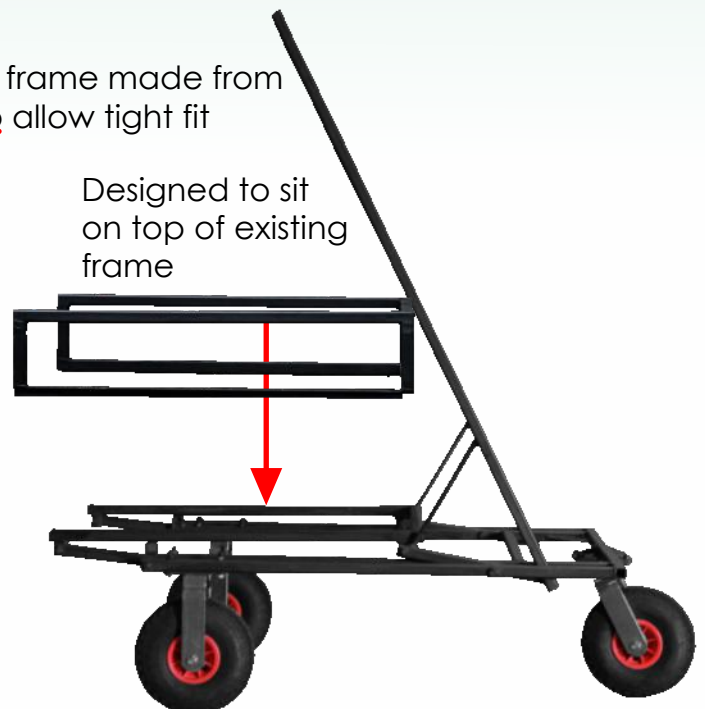
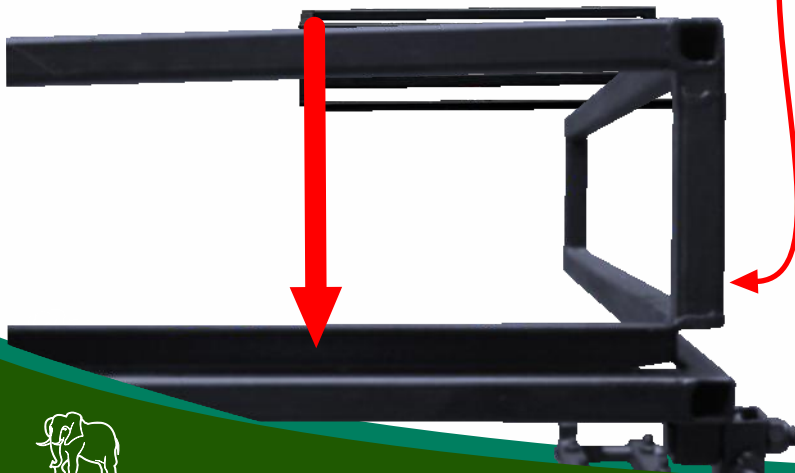

Sturdy Versatile Mortar

The Sturdy Versatile Mortar Tub 250Ltr is designed for crane, teleporter and standard forklift use. It can be top and bottom lifted by a forklift.

The frame is secured to the tub body by steel rivets and large steel washers. The flexible body of the container facilitates ease of cleaning.

The Versatile Mortar Tub comes complete with a galvanised high grade steel frame and rigid handles. These rigid handles prevent the mortar tubs from locking together when stacked.

The Versatile Mortar Tub is fully and independently certified.



Versatile LiftTub:

Capacity
250L

Width
762mm

Length
1070mm

Height
555mm

Product Code
364- A

Radon Sump

- Protects your building from the harmful effects of this naturally occurring gas.
- Prevents radon from rising in cavities of hollow concrete block walls.
- A single extraction pipe is run off from the sump and it is possible in longer buildings to connect sumps in sequence.
- Four outlets allow you to have the extraction pipe where it is ideal.



Technical Specifications:

Pipe diameter:
110mm

Width:300mm

Length: 600mm
(825mm overall)

Height:230mm

Product Code
166- A

Tipping Wheelbarrow



1. Wheelbarrow is balanced so it is easy to manoeuvre even when fully loaded.



2. Lift handles of barrow until the bucket tilts forward away from the frame.



3. Bring frame back towards the ground and the bucket will tilt forward fully, emptying contents.

Technical Specifications:

Capacity
310L

Width
1020mm

Length
1870mm

Height
850mm

Product Code
338- A

Sturdy Mini Skip

The Sturdy Mini Skip is cost effective and practical. It is easy to manoeuvre and can be lifted by crane or teleporter.

Manufactured from medium density polyethylene UV stabilised the Mini Skip is extremely strong and durable. The frame is secured to the body of the skip by steel rivets and large steel washers. The flexible body of the container facilitates ease of cleaning. The Mini Skip comes complete with a steel frame and unique patented Sturdy "Flexi-Handles". An additional steel frame cage is added to allow for an extra load. All components of the frame are fully galvanised. The Mini Skip can also be hot foiled stamped with a unique serial number which gives security and traceability over your tubs. Its bottom handles facilitates the emptying of the contents into large waste skips on site.



Mini Skip

Capacity: 500Ltr

Width 900mm

Length 1000mm

Height 700mm

Product Code
331 - A

Forkliftable Bulk Container

The unique design of the Sturdy Forkliftable Bulk Container makes it ideal for storing or transporting material of all types.

- Strong, durable and practical for many types of storage and transportation.
- Lightweight and easy to manoeuvre.
- Drain plugs can be fitted as an optional extra.
- Personalisation available upon request.
- Manufactured from UV stabilised polyethylene plastic.
- **Optional extras**
Castors and handles are available as optional extras.



Technical Specifications:

Capacity
900L

Width
1200mm

Length
1100mm

Height
960mm
(1200mm with castors)

Product Code
090 - A

Jobber

The Sturdy Jobber is manufactured from UV stabilised Polyethylene and is tough and durable. It has no sharp corners and is strong to withstand abuse.

The Jobber can be forklifted and is designed for the small builder. It fits neatly into the back of most vehicles. It can also be used to move small quantities of mortar or plaster by forklift.



Technical Specifications:

Capacity
200L

Width
900mm

Length
900mm

Height
380mm

Product Code
181 - A

Site Waste Segregation

The Sturdy Site Waste Segregation Trolleys are ideal for segregating waste on site. Substantial savings can be made by segregating construction waste on site.

- Both the *STURDY* Mini Skip and Waste Segregation Trolley are available in a range of standard colours in order to distinguish between different waste types.
- Both products are suitable for teleporter & crane lifting.
- The waste segregation trolley is fitted with 2 braked and 2 non-braked castors and has a coated steel frame. All components of the mini skip frame are fully galvanised.
- Both waste segregation products are fully and independently certified and incorporate our unique patented "Flexi" handles.

Personalisation is available on request.



Waste Segregation Trolley

Width:1000mm

Length:1670mm

Overall Height:
(Incl castors and handles): 1110mm

Product Code:390- A

Tipping Segregation Skip / Trolley

Both units are designed to help your business work smarter in the movement of material.

Integrated crane lifting points and tipping points for ease of movement.

Reinforced tipping front giving a long working life to the product.

Steel frame to give a robust long and safe working life to the product.

The Tipping Segregation Trolley has heavy duty Wheels ideal for moving around site.

Tipping Segregation Skip

Width:970mm

Length:2070mm

Height:750mm

Product Code
686- A



Tipping Segregation Trolley

Width:970mm

Length:2070mm

Height:920mm

Product Code
686- A



The STURDY Builders Chute is an ideal waste removal system that can be used in many different areas of the construction industry.

Ideal for the removal of site waste in all areas of the construction industry and helps keep work areas relatively dust free.

The system is suitable for any scaffolding height.

It is a strong and durable waste removal system which can be easily assembled without removing scaffolding boards.

The top or starter chute can be fitted with a metal frame that attaches to scaffolding.

All metal parts are galvanised to prevent against rusting.



An intermediate chute is also available. This allows entry to the system on different scaffolding levels. A fixing frame is also available for this section to reinforce the system.

The chute section incorporates signage panels which allow for personalisation with a company's corporate logo to advertise and promote the company. Available in a range of colours.

The plastic sections are manufactured from a U.V. stabilised medium density polyethylene and are fully recyclable.

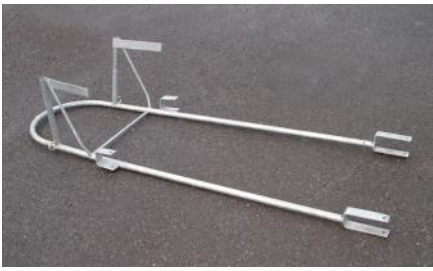

Normally 3 chute section and an Intermediate section are required per floor height

Top Section	Technical Specifications:	Intermediate Section	Technical Specifications:
	<p>Diameter:700mm Length:700mm Height:750mm Product Code 219- A</p>		<p>Diameter:700mm Length:1100mm Height:1090mm Product Code 220- A</p>
Chute Section	Technical Specifications:	Fixing Frames	Technical Specifications:
	<p>Diameter 700mm Height 1100mm Product Code 221- A</p>		<p>Upper and Intermediate Frames Product Code 222- A</p>

Road Barrier System

The Sturdy Road Guard Barrier System is the ultimate in function and convenience. It is a safer and a more practical alternative to posts or cones. It is also more convenient than concrete or steel barriers as no heavy lifting equipment is needed. The Road Guard Barrier has a low centre of gravity and can be filled with water to 'anchor' it in place. The Road Guard Barrier can also be secured to asphalt or concrete by a unique clamping system. Holes are strategically placed to prevent the barrier being overfilled and becoming too heavy to be manually handled. Unique stacking features help during transportation and storage. Forklift slots allow for lifting of stacked units. Each Road Guard Barrier weighs less than the recommended manual handling load and can be easily arranged by just one person. 100 units give 200 linear meters of continuous 'no gap' barrier, which can be delivered to site on one 40ft trailer. Removing the large 150mm rubber fill cap on the top of the Road Guard Barrier allows each unit to be filled with ease. A smaller rubber plug is located at the bottom of each unit to allow it to be emptied without the need to tip it over. The unit is manufactured from UV stabilised polyethylene and is 100% recyclable. The system is effective in all weather conditions. The UV stabilised polyethylene plastic will not discolour in sunlight.

The Road Guard Barrier is ideal for traffic re-routing, building and construction sites, temporary road closures, car parks, contra flow systems, airport/ferry terminals, sports or special events and footpath detours.



Road Guard

Width:	660mm
Length:	2430mm
Road Coverage:	2000mm
Height:	870mm
Code:	384-A



Starter Road Guard

Width:	720mm
Length:	600mm
Height:	1320mm
Code:	385-A



Intermediate Road Guard

Width:	720mm
Length:	1150mm
Road coverage:	650mm
Height:	1320mm
Code:	387-A



End Road Guard

Width:	660mm
Length:	975mm
Height:	800mm
Code:	386-A

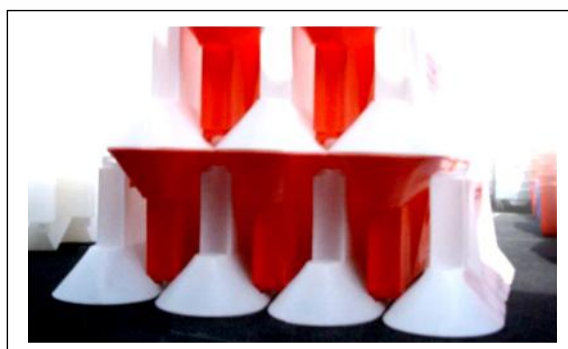

Tanks

Sturdy Products plastic tanks range in sizes from 290LT to 10,000LT and are suitable for potable water, oil, and chemical storage. Other tank sizes available upon request, please contact our sales team for more information. Or visit our at www.sturdyproducts.com

The tanks are manufactured from UV stabilised Medium Density Polyethylene.

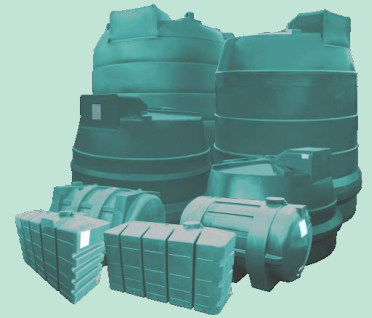

The Sturdy Balance Tank

The Sturdy Balance Tank is ideal for use as an extra storage container for water, oil, diesel, chemicals or as a pump housing chamber. An access screw cap is located on the top of the oil tank or water tank. The water storage tank or oil storage tank should be completely supported underneath. It can be manufactured from WRC approved UV stabilized medium density polyethylene material which is suitable for water storage. The tank is strong, durable and will never rust or require painting. As an optional extra a drainage bung or tap can be fitted upon request. The storage tanks are available in blue or black as standard and comes in three sizes - 290Ltr, 390Ltr and 450Ltr.



Balance Tank
Capacity: 290Ltr
Length: 805mm
Width: 570mm
Height: 860mm
Product Code 216-A

Balance Tank
Capacity: 390Ltr
Length: 980mm
Width: 570mm
Height: 860mm
Product Code 215-A

Balance Tank
Capacity: 450Ltr
Length: 1040mm
Width: 570mm
Height: 860mm
Product Code 214-A

Sturdy 850lt Water Tank



Sturdy 850lt Water Tank
Length: 1,000mm
Width: 675mm
Height: 1,610mm
Product Code 456-A

The Sturdy 850lt Water Tank is manufactured from WRC approved material and is suitable for the storage of potable water. The material is strong, durable, compounded UV stabilised medium density polyethylene which will never rust, fade or require painting.

This water tank is also perfect for collecting rainwater from gutters or buildings and is stored at ground level. Its ideal for all types of industry, from car washes, golf courses, hotels, farms and also areas prone to low water pressure.

The 850lt Tank should be completely supported underneath. A concrete base or concrete lintels are ideal and should protrude at least 2 inches past the tank on all sides.

Sturdy Booster Coffin Water Tanks 340LT / 500LT

The tanks are manufactured from UV Stabilised Medium Density Polyethylene which has been approved by the Water Regulations Advisory Scheme (WRAS)

The U.V. Stabiliser has a rating of 8 (i.e. Sunlight Stabilised, Good Colour Retention, and Long Life Expectancy).

The colour is compounded into the material.

Optional Extras

- Bylaw 30 kit, Inlet and outlet fittings
- Bund / drip tray available

Booster Coffin Water Tanks 340LT

Length: 1,500mm

Width: 600mm

Height: 630mm

Weight: 22kg

Product Code
671-A

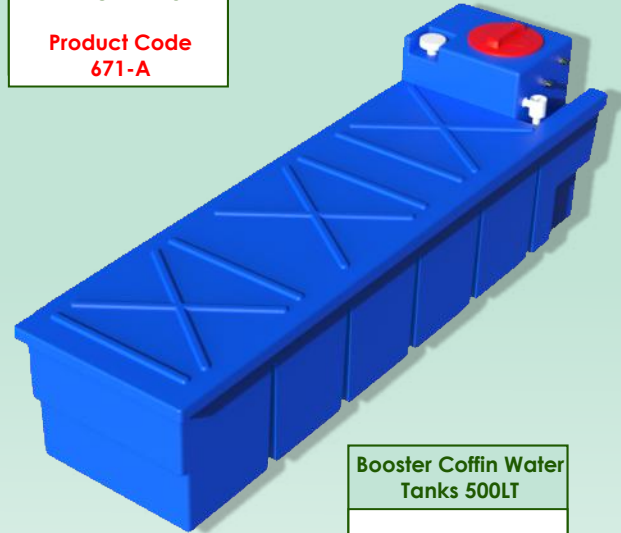
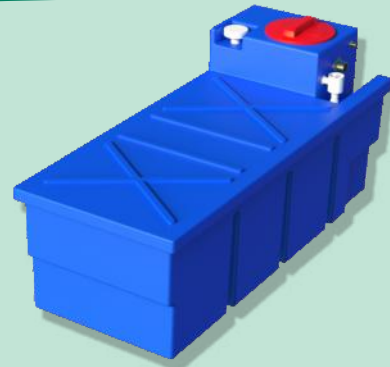

Booster Coffin Water Tanks 500LT

Length: 2,200mm

Width: 600mm

Height: 630mm

Weight: 34kg

Product Code
672-A

Sturdy 340LT / 500 LT Booster Tank

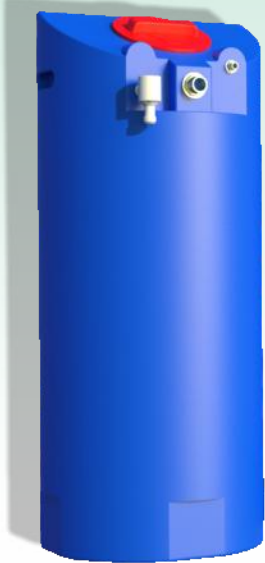

Sturdy 340LT Booster Tank

Diameter: 560mm

Height: 1380mm

Weight: 14kg

Product Code
629-A

Sturdy 500LT Booster Tank

Diameter: 750mm

Height: 1600mm

Weight: 20kg

Product Code
670-A

The tank is manufactured from UV Stabilised Medium Density Polyethylene which has been approved by the Water Regulations Advisory Scheme (WRAS)

The U.V. Stabiliser has a rating of 8 (i.e. Sunlight Stabilised, Good Colour Retention, and Long Life Expectancy).

The colour is compounded into the material.

Optional Extras

- Bylaw 30 kit, Inlet and outlet fittings
- Bund / drip tray available

Tanks and Storage

Sturdy Products plastic tanks range in sizes from 290LT to 10,000LT and are suitable for potable water, oil, and chemical storage. Other tank sizes available upon request, please contact our sales team for more information.

The tanks are manufactured from UV stabilised Medium Density Polyethylene.

JXL Bunded Tank

The JXL Bunded Tank when used gives peace of mind knowing that the surrounding environment is protected from accidental pollution from leaks or spillages. The bunded tank is capable of holding 110% of the oil storage tank's contents.

The bund has a large lockable lid for easy access to the internal oil storage tank. Manufactured from UV stabilised medium density polyethylene plastic it will never rust. It is strong and designed to withstand demanding environmental requirements.

It is recommended that all domestic installations for oil storage should be bunded. However all commercial, industrial, educational, agricultural and institutional properties using and storing oil and commercial fuels must use a bunded oil storage tank.



JXL Bund
Capacity: 2750L
Length: 2400mm
Width: 1700mm
Height: 1490mm
Product Code 150- A

Sturdy Bunded tanks range from 1200LT to 10,100LT
See details on www.sturdyproducts.com

Sturdy 10,100 Water Tank

The Sturdy 10,100 Water Tank is manufactured from WRC approved material and is suitable for the storage of potable water. This water tank is ideal for the collection of rainwater from gutters or buildings and is stored at ground level.

This water storage tank is manufactured from strong, durable, compounded UV stabilised medium density polyethylene. This water storage tank will never rust or require painting.

The Sturdy 10,100 Water Tank should be completely supported under its entire length and width. A concrete base or concrete lintel is ideal and should protrude at least 2 inches past the tank on all sides, as per the instructions moulded on each tank.



10,100L Water Tank
Capacity: 10100L
Diameter: 2500mm
Height: 2815mm
Product Code 366- A

Sturdy Water Tank range from 1200LT to 10,100LT
See details on www.sturdyproducts.com

Sturdy Super IBC Bund

Our Sturdy Super IBC Bund is designed to safely store IBC Tanks. Its unique design allows for the tank to be stored in a controlled and save manner due to it's anti-spill lip which can hold up to 1300lt of liquid in case of a leak.

We have a range of other Chemical Store products available
See details on www.sturdyproducts.com



Sturdy Bunded IBC Store
Capacity: 5.8m3
Width: 1,950mm
Depth: 1,565mm
Height: 1,900mm
Product Code: 660-A



Looking forward to hearing from you!

STURDY PRODUCTS LIMITED
Blessington Industrial Estate,
Blessington,
Co. Wicklow,
Ireland

Contact Details:

Tel: 00 353 45 865044

Fax: 00 353 45 865721

E-mail: sales@sturdyproducts.com

Website: www.sturdyproducts.com

